



TIP-OUT TRAY SYSTEM INSTALLATION INSTRUCTIONS

Rev-A-Shelf, L.L.C.

2409 Plantside Dr. • Jeffersontown, KY 40299 • (800) 626-1126 • www.rev-a-shelf.com



SELF-HOLDIN' HINGE INSTALLATION

- Step 1:** Remove front panel or panels from sink cabinet.
- Step 2:** Install the hinges to both sides of the cabinet as shown in Figure A. Locate the front edge of the hinges flush with the outside of the cabinet and install the flat head screws provided in the approximate middle of the elongated holes. This will allow for a future "up and down" adjustment of $\frac{3}{16}$ ".
- Step 3:** Mark the back of the panel with the cabinet opening less the $\frac{1}{16}$ " distances shown in Figure B. Both marks should be equal from the sides.
- Step 4:** Measure the height of the elongated slots using the original panel position as your reference point. Mark the panel. Install the panel to the hinges using the Truss Head Screws provided.

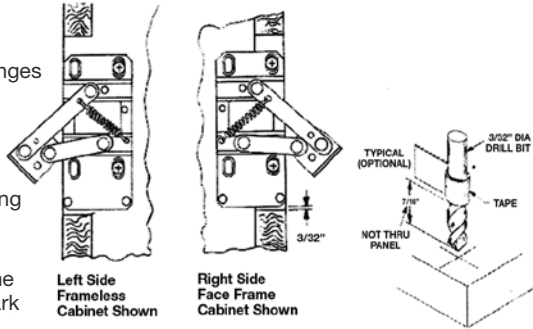

Figure A

Figure B

These instructions also apply to the following: TOT18S - TOT60S and TOT36W

USE FOR TOT18S - TOT60S

STAINLESS TRAY INSTALLATION

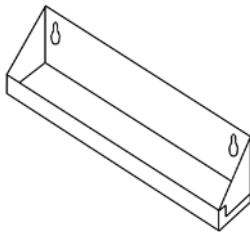

- Step 5:** Close the panel, reach inside the cabinet and draw a line across the top of the frame opening on the back of the panel. Open the hinged panel and draw another line $\frac{1}{8}$ " below the top of the Tip-Out Tray.
- Step 6:** Place the top of the tray against your gaging line, centered between the hinges, and mark the center of the top portion of the mounting holes. Apply the screws of sufficient depth to allow removal of tray or future cleaning.
- NOTE:** In most cases it is easier to remove the panel from the hinges for tray installation, reinstall and adjust the panel and then slip the tray on the screws.

TOOLS REQUIRED:

- #2 Phillips Screw Driver
- Optional Drill and $\frac{3}{32}$ " Drill Bit
- Fine Tooth Saw (For Custom Trays)
- Block of Wood (For Custom Trays)

HELPFUL HINTS:

- A. A small amount of bar soap on the screw threads will reduce the initial installation effort.
- B. Pre-installation of the screws or pre-threading into holes will also ease final installation.
- C. Your new trays are made from a Hi-Impact Polymer and may be cleaned using mild soap and water. Avoid scalding water, harsh abrasives and dishwashers.

USE FOR TOT36W

CUSTOM POLYMER TRAY INSTALLATION

For Hinge Installation see Step 1 thru 4

- Step 5:** The 36" tray in most applications will have to be cut to the proper length. To obtain proper length, measure the opening width, then subtract $1\frac{1}{2}$ " from the opening width and cut tray accordingly.

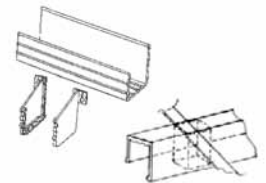

Figure C

- Step 6:** With adhesive provided (please read warnings and directions on adhesive tube), apply all the way around the inside of the end cap channels, which should sufficiently hold the end caps in place.
- Step 7:** After adhesive has set, locate on end caps as shown in Figure D. Mark panel, drill and mount screws to sufficient depth to allow removal of the tray for future cleaning.

WARNING: If tray is to be shipped installed in cabinet TAPE SECURELY TO PANEL.

Refer to preceding note and helpful hints for easier installation.

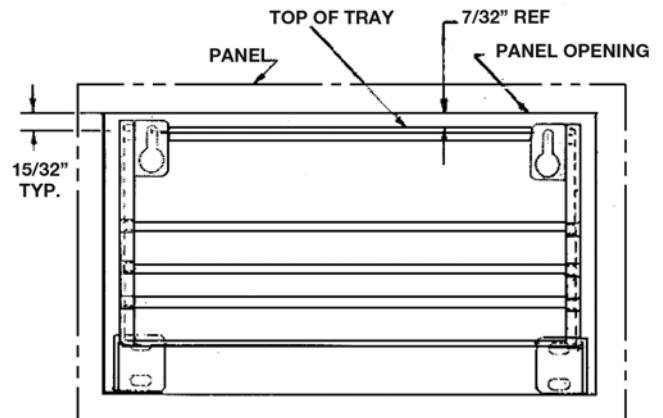

Figure D

